

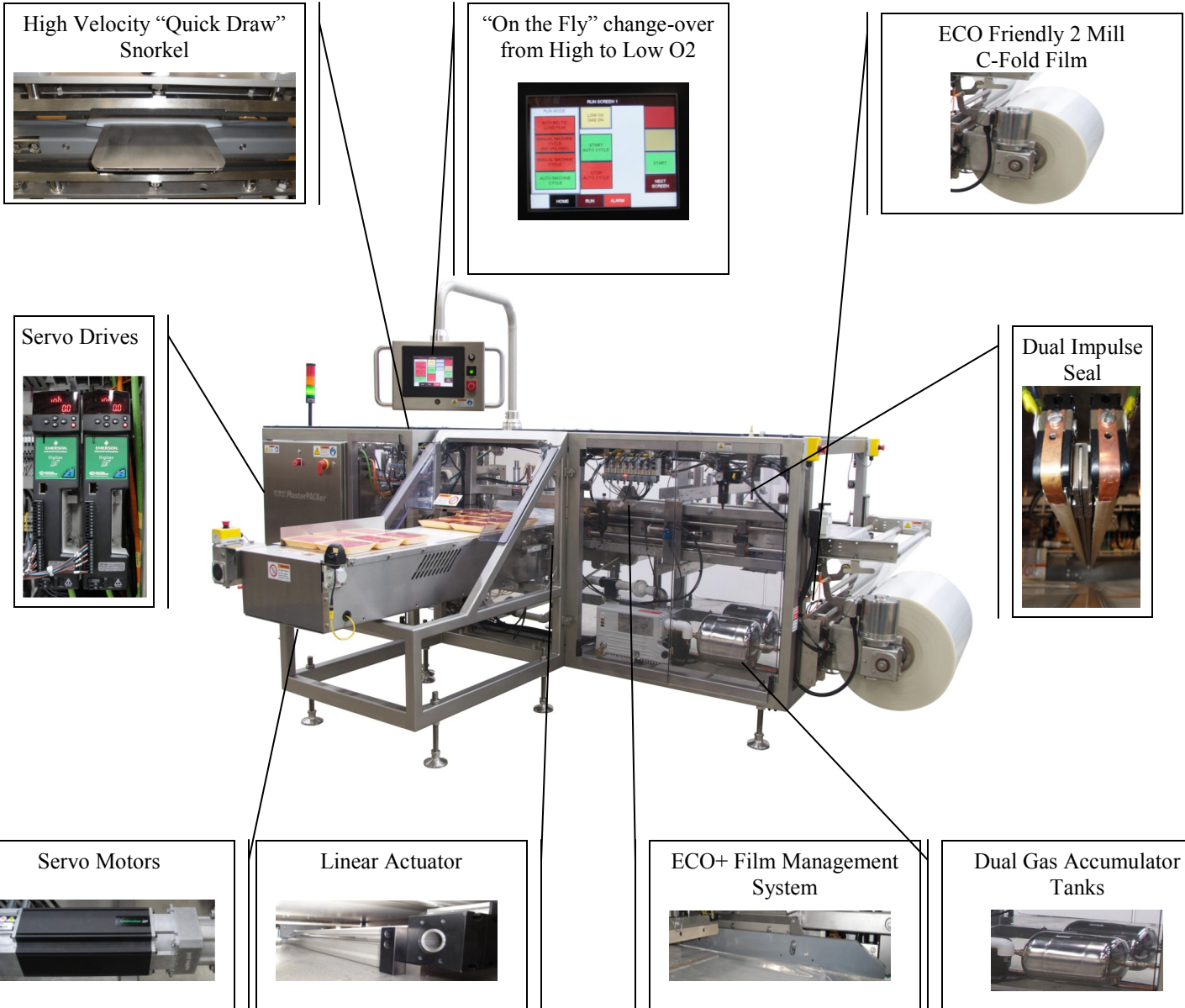

The secret to your success in MAP case ready packaging is CVP 's ECOplus™ (or ECO+™) family of products. The ECOplus™ (or ECO+™) combination of equipment and materials technology working in concert provide you the best in high speed production with a small carbon footprint. This includes the MasterPacker eco+® (or MasterPacker ECOplus™) featured in this brochure as well as complementary ECOplus™ (or ECO+™) packaging materials and solutions.

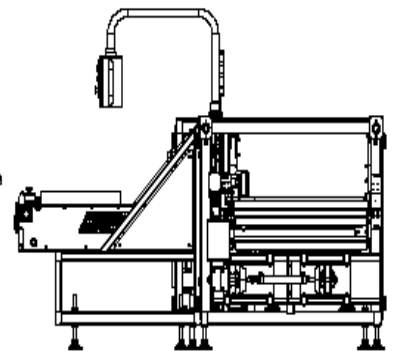

*Cutting edge technology from the leader in modified atmosphere packaging.
Made with pride in the USA since*

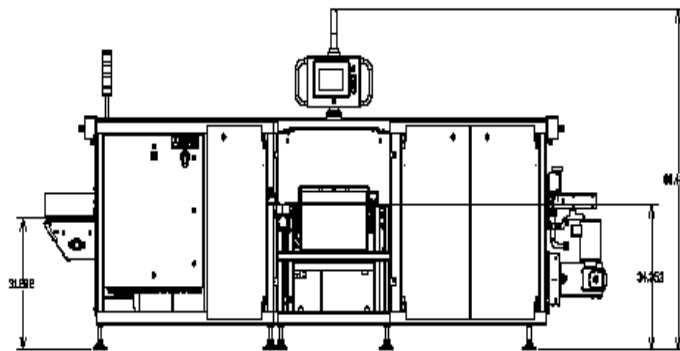
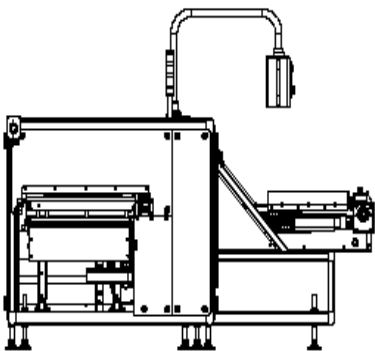
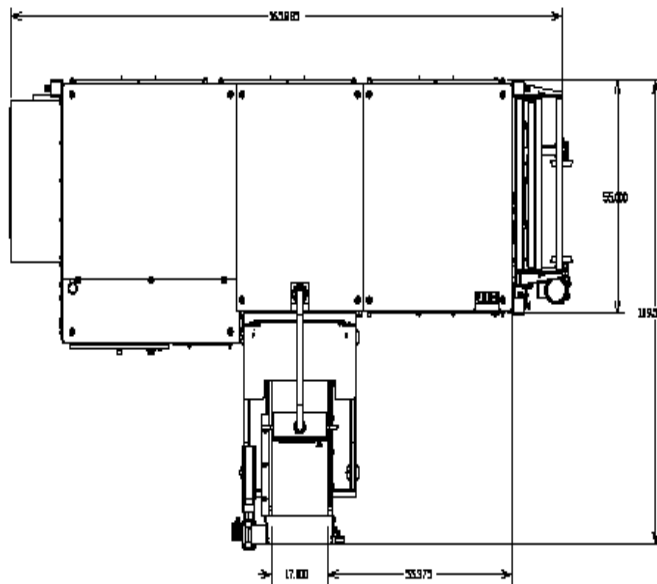

Design Features

- Significant cost reduction resulting from labor elimination and improved efficiencies
- Improvement of overall line efficiencies resulting from elimination of bottle necks
- Better continuous product flow
- Eliminate use of carrier cases
- Cost benefit of more efficient utilization of C-fold film as compared to pre-made bags
- Better space utilization due to small system footprint
- Improved product quality and consistency
- High O₂ and low O₂ processing
- Residual O₂ less than 1/2% with low O₂ settings
- PLC control of gas fill rates for consistent back-flush
- Excellent ergonomics
- Consistent seal quality and O₂ levels
- Product is presented to the snorkels same way every time, giving consistent results
- Stainless steel construction
- Complete wash-down inside and out
- Clean in Place system



2518 Wisconsin Avenue
Downers Grove, IL 60515 USA
Phone: (630) 852-1190
Website: www.cvpsystems.com
Email: sales@cvpsystems.com